



DRAFT

Health and Safety Handbook

March 2026

worknest
H&S

CONTENTS

INTRODUCTION	4
HEALTH AND SAFETY POLICY STATEMENT	5
RESPONSIBILITIES AND RULES	6
Employee Responsibilities.....	6
Health and Safety Rules.....	7
General	7
Working Practices	7
Hazard / Warning Signs and Notices	7
Working Conditions / Environment	7
Protective Clothing and Equipment	7
Fire Precautions	8
Accidents	8
Health.....	8
Rules Covering Gross Misconduct	8
ARRANGEMENTS FOR HEALTH AND SAFETY	9
Accident, Incident and Ill-Health Recording, Reporting and Investigation	9
Communication and Consultation	9
Contractors.....	9
Disabled Persons	10
Display Screen Equipment	10
Driving for Work	10
Drugs and Alcohol.....	11
Electricity.....	12
Fire.....	12
Fire and Emergency Evacuation Procedure	14
First Aid.....	15
Gas Installations and Appliances.....	15
Hazardous Substances (COSHH)	16
Health, Safety and Welfare.....	16
Home Working	17
Infection Control	17
Legionnaires' Disease	18
Leptospirosis (Weil's Disease).....	18
Lifting Operations and Equipment	19
Lone Working	19
Machinery Maintenance	19
Manual Handling	20
New and Expectant Mothers	20
Outdoor and Peripatetic Working.....	20
Personal Protective Equipment	21
Risk Assessment.....	21
Smoking	21
Stress at Work.....	22
Training	22
Violence to Staff	22
Visitors	23
Waste Management	23
Work At Height	23
Work Equipment.....	24
Control of Substances Hazardous to Health (COSHH).....	24
Display Screen Equipment (DSE).....	27
Driving	28
Electrical Safety	34
Hand Washing.....	35
Ladders and Stepladders	35

Lone Working 41
Manual Handling 44
Violence and Aggression..... 45

INTRODUCTION

This handbook contains the health and safety information you require to comply with our Health and Safety Policy. After reading it you will be required to sign to confirm that it has been brought to your attention. If you have any queries regarding the contents, please do not hesitate to ask.

The Council takes its responsibility for health and safety very seriously and is committed to a programme of progressive improvement that requires input from all its employees. If you see anything during your work that gives rise to a concern you are positively encouraged to report it to your manager.

Safety is everyone's responsibility and that includes you.

HEALTH AND SAFETY POLICY STATEMENT

Hassocks Parish Council recognises that it has a legal duty of care towards protecting the health and safety of its employees and others who may be affected by the Council's activities, and that managing health and safety is a business-critical function.

In order to discharge its responsibilities, the Council will:

- bring this Policy Statement to the attention of all employees;
- carry out and regularly review risk assessments to identify proportionate and pragmatic solutions to reducing risk;
- communicate and consult with our employees on matters affecting their health and safety;
- comply fully with all relevant legal requirements, codes of practice and regulations at international, national and local levels;
- eliminate risks to health and safety, where possible, through selection and design of materials, buildings, facilities, equipment and processes;
- encourage staff to identify and report hazards so that we can all contribute towards improving safety;
- ensure that emergency procedures are in place at all locations for dealing with health and safety issues;
- maintain our premises, provide and maintain safe plant and equipment;
- only engage contractors who are able to demonstrate due regard to health & safety matters;
- provide adequate resources to control the health and safety risks arising from our work activities;
- provide adequate training and ensure that all employees are competent to do their tasks;
- provide an organisational structure that defines the responsibilities for health and safety;
- provide information, instruction and supervision for employees;
- regularly monitor performance and revise policies and procedures to pursue a programme of continuous improvement.

This Health and Safety Policy will be reviewed at least annually and revised as necessary to reflect changes to the business activities and any changes to legislation. Any changes to the Policy will be brought to the attention of all employees.

Signed:

Dated:

Name:

Position:

Chair of the Council

RESPONSIBILITIES AND RULES

Employee Responsibilities

It is the responsibility of all employees to co-operate in the implementation of this Health and Safety Policy within their areas of influence. All employees have a legal duty to ensure their own safety and the safety of others (for example, colleagues, visitors, contractors) under the Health and Safety at Work etc Act.

Employees must therefore:

- take reasonable care of their own safety;
- take reasonable care of the safety of others affected by their actions;
- observe the safety rules;
- comply with the Health and Safety Policy;
- conform to all written or verbal instructions given to them to ensure their personal safety and the safety of others;
- dress sensibly and safely for their particular working environment or occupation;
- conduct themselves in an orderly manner in the work place and refrain from any antics or pranks;
- use all safety equipment and/or protective clothing as directed;
- avoid any improvisations of any form which could create an unnecessary risk to their personal safety and the safety of others;
- maintain all equipment in good condition and report defects to their manager;
- report any safety hazard or malfunction of any item of plant or equipment to their manager;
- report all accidents to their manager whether an injury is sustained or not;
- attend as requested any health and safety training course;
- observe all laid down procedures for processes, materials and substances used;
- observe the fire evacuation procedure and the position of all fire equipment and fire exit routes.

Health and Safety Rules

General

- It is the duty of all employees to co-operate with management in fulfilling our legal obligations in relation to health and safety;
- Employees must not intentionally or recklessly interfere with anything provided in the interests of health, safety or welfare;
- Employees are required to notify to management of any unsafe activity, item or situation.

Working Practices

- Employees must not operate any item of plant or equipment unless they have been trained and authorised;
- Employees must make full and proper use of all equipment guarding;
- Employees must not clean any moving item of plant or equipment;
- Employees under the age of 18 years must not operate any item of plant or equipment unless they have received sufficient training or are under adequate supervision;
- Employees must not make any repairs or carry out maintenance work of any description unless authorised to do so;
- Employees must use all substances, chemicals, liquids etc, in accordance with all written instructions;
- Employees must not smoke except in prescribed areas.

Hazard / Warning Signs and Notices

- Employees must comply with all hazard/warning signs and notices displayed on the premises.

Working Conditions / Environment

- Employees must make proper use of all equipment and facilities provided to control working conditions/ environment;
- Employees must keep stairways, passageways and work areas clear and in a clean and tidy condition;
- Employees must dispose of all rubbish, scrap and waste materials within the working area, using the facilities provided;
- Employees must clear up any spillage or liquids within the work area in the prescribed manner;
- Employees must deposit all waste materials and substances at the correct disposal points and in the prescribed manner;

Protective Clothing and Equipment

- Employees must use all items of protective clothing/equipment provided as instructed;
- Employees must store and maintain protective clothing/equipment in the approved manner;
- Employees must report any damage, loss, fault or unsuitability of protective clothing/equipment to their manager;

Fire Precautions

- Employees must comply with all laid down emergency procedures;
- Employees must not obstruct any fire escape route, fire equipment or fire doors;
- Employees must not misuse any fire fighting equipment provided;
- Employees must report any use of fire fighting equipment to their manager.

Accidents

- Employees must seek medical treatment for work related injuries they receive by contacting a designated first aider. Upon returning from treatment they must report the incident to their manager;
- Employees must ensure that any accident or injury treatment is properly recorded as per Council policy;
- Employees must notify management of any incident in which damage is caused to property.

Health

- Employees must report to management any medical condition or medication which could affect the safety of themselves or others;
- Employees must co-operate with the management on the implementation of the medical and occupational health provisions.

Rules Covering Gross Misconduct

An employee will be liable to summary dismissal if they are found to have acted in any of the following ways:

- a serious or wilful breach of Safety Rules;
- unauthorised removal or interference with any guard or protective device;
- unauthorised operation of any item of plant or equipment;
- unauthorised removal of any item of first aid equipment;
- wilful damage to, misuse of or interference with any item provided in the interests of Health and Safety or welfare at work;
- unauthorised removal or defacing of any label, sign or warning device;
- horseplay or practical jokes which could cause accidents;
- making false statements or in any way deliberately interfering with evidence following an accident or dangerous occurrence;
- misuse of any item of equipment, utensil, fitting/ fixture, vehicle or electrical equipment;
- deliberately disobeying an authorised instruction.

ARRANGEMENTS FOR HEALTH AND SAFETY

Accident, Incident and Ill-Health Recording, Reporting and Investigation

An **accident** is an unplanned event that causes injury to persons, damage to property or a combination of both.

A **near miss/incident** is an unplanned event that does not cause injury or damage but could do so.

A **work-related illness** is a prescribed illness that is obtained by an employee through the course of work or from a non-employee as a result of activities carried out by the Council.

Reporting

All accidents resulting in personal injury must be reported as per council policy.

Incidents and work-related ill-health need to be reported directly to your manager.

Communication and Consultation

The Council has established effective lines of communication so as to involve and consult our employees.

These may include:

- individual conversations;
- notice boards;
- internal publications;
- staff meetings;
- Health and Safety meetings.



In addition, the Council will display the 'Health and Safety Law – What You Need To Know' poster in a prominent position.

The Council will consult with our employees and provide information on any changes that may affect their health and safety, including:

- changes in procedures, equipment or ways of working;
- the dangers and risks arising from their work activities, the measures taken to eliminate or reduce these risks and what action to take if they have to deal with them;
- the planning of health and safety training;
- the health and safety consequences of introducing new technology.

The Council recognises that consultation is a two-way process and expects constructive feedback from our employees.

Contractors

When working on our premises it is considered that contractors are joint occupiers for that period and therefore, we have both joint liabilities in "common areas". In order to meet our legal obligations with regard to contractors we will ensure that prior to engaging any contractor they are competent and that any works are carried out safely.

Similarly, we have a parallel duty to the contractor and must ensure that the contractor is not put at risk by our own activities for the duration of the contract.

If you observe contractors who appear to be working unsafely then you should report this immediately to a manager. We will investigate and where necessary stop any work until resolved.

Disabled Persons

The Council will give full and proper consideration to the needs of disabled employees and visitors.

To achieve this, the Council will:

- treat all disabled employees and visitors with respect and dignity, both in the provision of a safe working environment and in equal access to the organisation's facilities;
- ensure that risk assessments are undertaken of the special needs of the disabled and carry out reasonable adjustments to the premises and/or employment arrangements;
- encourage employees with special needs to suggest any premises or task improvements to their line managers;
- discipline any employees found treating their disabled colleagues with less than the expected standards of respect and dignity;
- in an emergency evacuation, ensure suitable plans are in place which will assist disabled people to leave the premises swiftly.

Display Screen Equipment

All reasonable steps will be taken by the Council to secure the health and safety of employees who work with display screen equipment.

To achieve this objective the Council will carry out an assessment of each user's workstation and implement necessary measures to remedy any risks found as a result of the assessment.

Eye Tests and Corrective Appliances

The Council will arrange for the provision of free eye tests when requested and at regular intervals thereafter or where a visual problem is experienced, at no cost to the employee. Where employees require corrective appliances specifically for use with display screen equipment, the Council will arrange for the supply of corrective appliances up to current cost limits.

Training

Employees working with display screen equipment (DSE) should comply with the instructions and training given regarding safe workstation set-up and use, including the need for regular changes of activity or breaks and the use of the equipment provided.

Health

Employees should inform their departmental line manager of any disability or health condition which may affect their ability to work using display screen equipment or be affected by working with DSE. In addition, they should also report to their departmental line manager any discomfort or health concern believed to be associated with the use of DSE. Any health information will be treated confidentially.

Driving for Work

Driving short distances is occasionally required for Council work. Driving has inherent risks associated with it which drivers should be made aware of.

The Council is committed to reducing the risks its staff face or create when driving at work and requires its entire staff to play their part.

Drivers

Drivers will remain responsible for their safety and others and must comply with the Highway Code and Road Traffic Act.

It is the responsibility of drivers to inform their manager of:

- anything that could affect their driving e.g. health conditions or injuries, use of prescribed medication;
- changes to licence such as; limitations, offences recorded, period bans;
- vehicle defects that affect ability / safety to drive;
- any accidents / incidents that occurred whilst driving on behalf of the Council.

Before driving, drivers must:

- review the need to travel;
- have a valid licence for the vehicle they are driving and ensure valid insurance for business use;
- be physically fit and have a level of alcohol below the maximum limit allowed, ideally zero and not under influence of any drugs that may affect the ability to drive;
- have had an eye test in last 2 years and be using any required corrective appliance;

Whilst driving, drivers must:

- drive in accordance with the applicable law and with consideration for the safety of passengers and other road users;
- remain in control of the vehicle at all times;
- only use hands free electronic devices e.g. mobile phone, satellite navigation, mp3 player, when safely set up to do so i.e. using an appropriate hands-free device;

Drugs and Alcohol

Alcohol

Employees must not drink alcohol on the Council's premises or the premises of its customers or clients without express permission from a senior manager or director.

Any employee who is found consuming alcohol on the Council's premises or the premises of its customers and clients without permission or is found to be intoxicated at work will normally face disciplinary action on the ground of gross misconduct under the Council's disciplinary procedure.

Drugs and medication

The possession, use or distribution of drugs for non-medical purposes on the Council's premises is strictly forbidden and a gross misconduct offence.

If you are prescribed drugs by your doctor which may affect your ability to perform your work you should discuss the problem with your manager.

If the Council suspects there has been a breach of this policy or your work performance or conduct has been impaired through substance abuse, the Council reserves the right to require you to undergo a medical examination to determine the cause of the problem.

Medical Examination

Existing and prospective employees may be asked to undergo a medical examination, which will seek to determine whether he/she has taken a controlled drug or has an alcohol abuse problem.

A refusal to give consent to such an examination or a refusal to undergo the screening will result in the immediate withdrawal of any offer made to prospective employees and will normally be treated as gross misconduct for employees.

If, having undergone a medical examination, it is confirmed that you have been positively tested for a controlled drug, or you admit there is a problem, the Council reserves the right to suspend you from your employment (with or without pay) to allow the Council to decide whether to deal with the matter under the terms of the Council's disciplinary procedure and/or to require you to undergo treatment and rehabilitation.

Reasonable Grounds

The Council reserves the right to search you or any of your property held on council premises at any time if there are reasonable grounds to believe that this policy is being or has been infringed or for any other reason. If you refuse to comply with these search procedures, your refusal will normally be treated as gross misconduct.

The Council reserves the right to inform the police of any suspicions it may have with regard to the use of controlled drugs by its employees on the Council's premises.

Electricity

All reasonable steps will be taken to secure the health and safety of employees who use, operate or maintain electrical equipment.

Employees must:

- visually check electrical equipment for damage before use;
- report any defects found to their line manager;
- not use defective electrical equipment;
- not carry out any repair to any electrical item unless qualified to do so;
- switch off non-essential equipment from the mains when left unattended for long periods;
- not bring any electrical item onto council premises until it has been tested and a record of such a test has been included in the appropriate record;
- not leave electric cables in such a position that they will cause a tripping hazard or be subject to mechanical damage;
- not carry out any live working unless authorised to do so under a permit-to-work.



Fire

All reasonable measures will be taken to prevent the outbreak of fire. In the event of fire, the preservation of life shall take precedence over all other considerations, including the protection of property and firefighting efforts.

While employees are not expected to attempt to extinguish a fire, they may do so **only** if it is safe and they have received appropriate training. Upon activation of the evacuation signal, all occupants must evacuate the building immediately and proceed to the designated assembly point(s).

Re-entry of the building is strictly prohibited until the Fire Service or a senior person present declares it is safe to do so.

Employees are encouraged to raise any concerns regarding fire safety so that the organisation can investigate and implement corrective actions where necessary.

Fire and Emergency Evacuation Procedure

IF YOU DISCOVER A FIRE:

Immediate Actions in the Event of Fire

- **Activate the nearest fire alarm call point** to alert others and initiate evacuation procedures.
- **Only attempt to fight the fire** if:
 - It is safe to do so,
 - You are authorised,
 - You have received appropriate training,
 - And a safe exit route is always maintained.
- **Do not attempt to extinguish the fire** if:
 - You are unable to control it,
 - Your escape route is compromised,
 - Or you are not trained or authorised.
- In such cases, **evacuate the building immediately** and proceed to the designated assembly point.



ON HEARING THE ALARM:



Evacuation Procedure

- **Immediately vacate the premises** using the nearest safe exit.
- **Close all windows and doors** behind you, if safe to do so, to help contain the fire and reduce the spread of smoke.



Assembly Point Procedure

- Proceed immediately to the designated **assembly point** upon evacuation.
- **Report to the person in charge** at your assembly point to confirm your safe evacuation.



Important Safety Instructions – Do Not Re-Enter

- Do not re-enter the building to collect personal belongings.
- Do not re-enter the building until instructed by the Fire Service or a designated senior person.
- Do not use lifts during an evacuation unless explicitly authorised to do so by emergency personnel.

Visitor Evacuation Procedure

All visitors must be escorted to the designated assembly point by their host.

Visitors should **not leave the assembly area** until they have reported to the senior person present and their safe evacuation has been confirmed.

Role of the Senior Person During an Emergency

The designated senior person present will meet and liaise directly with the emergency services and any other relevant parties. They will provide essential information regarding the emergency, including:

- The location and nature of the incident,
- The presence and location of hazardous or flammable materials,
- Headcount and evacuation status,
- Any other pertinent details to support emergency response efforts.

First Aid

The Council is committed to providing sufficient provision for first aid to deal with accidents and injuries that arise at work. To achieve this objective the Council will appoint and train a suitable number of first aid personnel to cover all work patterns and communicate their identities to all staff.

If you are interested in becoming a first aider or appointed person, please inform your manager.

Should you require first aid treatment, please contact your nominated first aider/appointed person. Please ensure all accidents have been recorded accordingly.



First Aid supplies

A first aid box will be provided and should be kept stocked. If you use any of the contents please inform the persons responsible for the contents. Portable first aid kits will be available for staff members required to work away from the normal workplace, where access to facilities may be restricted.

Gas Installations and Appliances

The Council will ensure that all work carried out on gas fittings and appliances are in accordance with the requirements of the regulations and the Safety in the Installation and Use of Gas Systems and Appliances Manual.

The Gas Safe Register (GSR), formerly CORGI, is the governing body approved by the Health and Safety Executive to register and monitor the activities of gas installation and use. Gas fitting operatives carrying out work on behalf of the Council will be registered with the GSR.



No person shall interfere with any gas appliance or gas fitting or pipe work unless qualified and competent to do so.

Gas Leak Procedure

If you smell gas or suspect you have a gas emergency, you **MUST** follow the steps below:

DO NOT

- operate any electrical switches (on or off);
- smoke or use a naked flame;
- turn the gas back on until the leak has been repaired.

DO

- extinguish all naked flames;
- open doors and/or windows to ventilate the area;
- check your gas appliances and turn them off;
- turn the gas supply off at the main meter;
- telephone the National Grid Emergency Service;
- evacuate the building;
- report to the Fire Assembly Point.

Fire

If a gas leak results in a fire on the premises:

- **IMMEDIATELY** activate the fire alarm, evacuating premises;
- **TELEPHONE** the Fire Service;
- **ISOLATE** the gas supply at the main meter if safe to do so;
- **TELEPHONE** the National Grid Emergency Service.

Hazardous Substances (COSHH)

All reasonable steps will be taken to ensure all exposure of employees to substances hazardous to health is prevented or at least controlled to within statutory limits.

The Council will give sufficient information and training to ensure full understanding of the hazards to health posed by substances in the workplace and the importance of the control measures provided. Information will also be given to others who may be affected such as contractors, temporary staff and visitors where appropriate.



Employees should **not** use any hazardous substance unless they have received the information and training for the safe use of that substance.



Health, Safety and Welfare

The Council is committed to providing suitable health, safety and welfare facilities in line with current legislation, in particular the provision of:

- adequate maintenance of workplace and equipment;
- appropriate ventilation, temperature control and lighting;
- suitable cleanliness and housekeeping standards;
- adequate workspace allocation;
- properly designed workstations;
- well maintained traffic routes and floors;
- appropriate fall protection;
- suitable glazing;
- safe access and egress (well maintained exits and entrances);
- appropriate sanitary and washing facilities;
- separate toilet facilities for men and women;
- plentiful drinking water supply and cups;
- seating with an incorporated back rest;
- accommodation for keeping clothing clean and dry;
- facilities for changing, rest periods, hot drinks and meals preparation;
- showering facilities if the nature of an employees work requires this;
- appropriate first aid provision;
- appropriate emergency, fire and evacuation equipment and procedures.

The Council recognises these responsibilities are required for any work whether on a remote work site, at their usual workplace or head office.

Home Working

Home workers are subject to the same health and safety requirements as workers based on council premises and their health and safety will be managed accordingly.

If you are a home worker, then you will be required to complete an assessment annually to review any requirements identified.

The assessment will review (but not limited to), equipment supplied, electrical testing, training, interaction with colleagues, communication.

Training

All home workers will be fully trained in the tasks that they are employed to do and the equipment they will be using.

Infection Control

For some work activities, staff may be at risk of infection or of spreading infection. The Council aims to prevent the spread of infection through work-based activities by adopting suitable control measures.

Employees must:

- follow any procedures set out and good hygiene practices;
- wear personal protective equipment (PPE) as directed.

Vaccination

Employees at risk of infection will where possible be offered vaccinations without charge. Please contact your manager to make arrangements.

Training and Information

Training and information will be provided to all employees who are identified from the risk assessment as being potentially exposed to infections. Training will be given for any tasks they are employed to do, the equipment they will be using and any safe procedures to adopt.

Staff Illness and Reporting

It is important to remember that infection can also be passed onto people from staff. Staff should notify their manager if they develop any infectious disease that may affect work or people around them, for example:

- skin infections or exposed areas of infestation;
- severe respiratory infection (e.g. pneumonia, TB);
- severe diarrhoea;
- jaundice;
- hepatitis;
- chicken pox, measles, mumps, rubella;
- norovirus;
- gastroenteritis;
- **HIV.**

Managers will need to discuss with the individual suitable controls. In some cases, employees may need to be referred to an Occupational Doctor or their GP for advice.

Staff should also report any illness or disease which has been contracted through work. In some circumstances if a staff member contracts a disease whilst at work, this is reportable under RIDDOR (Reporting of Injuries, Diseases and Dangerous Occurrences Regulations). Certain diseases including Leptospirosis, Hepatitis, TB, and Tetanus are specifically required to be reported.

Confidentiality

Confidentiality will be maintained at all times in relation to an employee who is known to have any infectious disease.

No health information will be disclosed without the written consent of the employee concerned and any breach of such confidentiality, either inside or outside the organisation, will be regarded as a disciplinary offence and may result in disciplinary action.

Pandemics and Epidemics

When notified that the country is experiencing a pandemic or epidemic, the Council will aim to prevent the spread of infection through work-based activities by adopting suitable control measures.

Employees must:

- assist the Council with implementing measures specified by government agencies, including adopting alternative methods of working such as home working where needed;
- use any required personal protective equipment (PPE) as instructed;
- ensure that they inform the Council about any relevant changes to their medical circumstances;
- adopt good hygiene practices.

Legionnaires' Disease

All reasonable steps will be taken to identify potential legionellosis hazards and to prevent or minimise the risk of exposure.

At risk systems include the hot and cold water storage and distribution system.

To achieve control of legionella bacteria the Council will implement measures to ensure any growth of the bacteria is kept to a minimum and systems maintained.

Leptospirosis (Weil's Disease)

Weil's Disease is a form of the bacterial infection Leptospirosis, which can be transmitted to humans through contact with rat urine. Employees are required to adhere to the following controls when working in areas that may be contaminated:

- cover any cuts or broken skin with the appropriate waterproof dressing, and wash cuts or grazes sustained during work immediately;
- wear the appropriate personal protective equipment as identified by the risk assessment;
- never touch or handle rats with bare hands;
- take rest breaks away from the work area;
- not consume food or drink in or near the work area;
- wash hands thoroughly after working in any environment that may have been contaminated with rat urine.

Any employee who suffers from feverish headaches, vomiting, muscle pains, and general flu-like symptoms after working in rat-contaminated areas must seek medical attention and inform their GP that they may have been in contact with rats or rat urine.

Lifting Operations and Equipment

All reasonable steps will be taken to ensure lifting operations and equipment are suitably managed with regards to health and safety.

Lifting equipment includes any equipment used at work for lifting or lowering loads, including attachments used for anchoring, fixing or supporting it.

Lifting equipment must only be used if:

- there is a safe working load displayed and the load is within the limit;
- it has been examined and tested prior to use and within examination scheme;
- there are no obvious signs of defects or damage;
- you have received information, instruction and training to do so.

Any damage to lifting equipment or accessories should be reported immediately to your manager and equipment taken out of use or signed appropriately.

Lone Working

The Council will ensure, so far as is reasonably practicable, that employees and self-employed contractors who are required to work alone or unsupervised for significant periods of time are protected from risks to their health and safety.

Employees and others will be given all necessary information, instruction, training and supervision to enable them to recognise the hazards and appreciate the risks involved with working alone.

Employees will be required to follow the safe working procedures devised including:

- when working alone, e.g. in an isolated area of a building with all doors closed, ensure that someone is aware of your presence;
- check that work being done has been subject to risk assessment and check the assessment yourself – some work may have been identified as requiring the assistance of a second person;
- if possible and arranged beforehand, keep in regular contact with someone else, e.g. use a mobile phone to call into the office every couple of hours indicating your movements;
- do not put yourself at risk; if you do not feel safe discuss the situation with your immediate manager;
- report all accidents, injuries, near-misses and dangerous occurrences to your immediate manager.

Machinery Maintenance

The Council will take all reasonable steps to ensure the safety of all employees maintaining the machinery as well as the safety of those affected by the maintenance work. The Council will liaise with the suppliers of all new machinery to establish how that machinery should be maintained safely

The Council will give sufficient information, instruction and training as is necessary to ensure the health and safety of all maintenance staff and any others affected by maintenance of the machinery.

No employee must carry out any repair or operate any machinery for which they have not been trained.

Manual Handling

To prevent injuries and long-term ill-health from manual handling the Council will ensure that operations which involve manual handling are eliminated, so far as is reasonably practicable. Where it is not practical the Council will carry out an assessment to determine what control measures are required to reduce the risk to an acceptable level. In considering the most appropriate controls, an ergonomic approach to designing the manual handling operation will optimise the health, safety and productivity associated with the task.

Information and Training

Adequate information and training will be provided to persons carrying out manual handling activities including details of the approximate weights of loads to be handled and objects with an uneven weight distribution

Health

No employee will be required to lift any item that they do not feel confident of doing without risking personal injury.

Employees who have a medical condition that may prevent them undertaking a task should notify their manager beforehand. Should you become injured whilst handling anything then this must be reported to your manager so it can be suitably investigated.

New and Expectant Mothers

The Council recognises that the general precautions taken to protect the health and safety of the workforce as a whole may not in all cases protect new and expectant mothers and there may be occasions when, due to their condition, different and/or additional measures will be necessary.

Should you become pregnant or are returning to work after having a baby, then you are requested to notify your manager at the earliest possible opportunity so a risk assessment can be carried out.

Any necessary control measures will be implemented and reviewed regularly. Where risks cannot be eliminated or reduced to an acceptable level then consideration will be given to adjusting working conditions and/or hours or if necessary providing suitable alternative work or suspension with pay.

New or expectant mothers should inform their manager of any changes which may affect the risk assessment including any medical conditions, incidents etc.

Outdoor and Peripatetic Working

The Council will ensure, so far as is reasonably practicable, that employees who work outdoors or away from their normal base are not put at any additional risk to their health and safety.

Staff working outdoors, or away from base, are responsible for ensuring that:

- if working on a third-party site, they report to a responsible person to ensure familiarisation with safety precautions relating to the particular site;
- they report any problems or shortcomings to their manager as soon as possible. If, during work, the conditions change or any aspect of the task changes in such a way to increase the risk, work should stop, unless doing so presents a greater risk;
- the appropriate personal protective equipment provided is worn correctly and when required to do so. Any defects must be reported to their manager;
- they are familiar with the emergency arrangements and that these are in place prior to starting work;

- all accidents and incidents are reported to their manager and in line with any local arrangements for the site.

Personal Protective Equipment

The Council provides personal protective equipment (PPE) when the risk presented by a work activity cannot be eliminated or adequately controlled by other means. When it is provided, it is because health and safety hazards have been identified that require the use of PPE and it is therefore necessary to use it in order to reduce risks to a minimum.

Employees provided with PPE must:

- wear the PPE as instructed or where indicated by signage;
- maintain it in good condition;
- report any defects to your manager;
- ensure the PPE fits correctly, is comfortable and fully adjusted.



Employees may also be required to remove jewellery or other small items when using PPE. Employees must remove such items as instructed; employees with concerns about removing items worn for ethical, philosophical or cultural reasons should speak to their manager.

Risk Assessment

Risk Assessment involves identifying the hazards present in the workplace or arising out of any work activity and evaluating the extent of the risks involved to employees and others, taking into account existing precautions and their effectiveness. The Council will arrange for competent people to carry out risk assessments of all activities, substances, equipment, plant or working conditions likely to give rise to a significant risk of injury or ill health.

Employees will be advised as to the results of the risk assessment process and the additional control measures to be implemented to reduce risk to an acceptable level. Employees are expected to support the risk assessment process and adopt any changed controls implemented to reduce risk to an acceptable level.

Smoking

Exposure to second-hand smoke, also known as passive smoking, increases the risk of lung cancer, heart disease and other illnesses. Ventilation or separating smokers and non-smokers within the same airspace does not stop potentially dangerous exposure.

It is the policy of the Council that all of its workplaces are smoke-free and that all employees have a right to work in a smoke-free environment.

Smoking is prohibited throughout the entire workplace and this includes the use of all artificial smoking aids (electronic or otherwise) with no exceptions. This includes council vehicles that are used by more than one employee. If you have a council car that is designated for your sole use and that is never used by other employees then you can smoke in it if you wish – but the Council recommends that you do not do so. This policy applies to all employees, customers and visitors.



Implementation

All staff are obliged to adhere to and facilitate the implementation of the policy.

The Council will ensure that all employees and contractors are aware of the policy on smoking. They will also ensure that all new personnel are given a copy of the policy on recruitment or induction.

Appropriate 'no smoking' signs will be clearly displayed at or near the entrances to the premises. Signs will also be displayed in council vehicles that are covered by the law.

Stress at Work

The Health and Safety Executive define stress as “the adverse reaction people have to excessive pressure or other types of demand placed on them”. This makes an important distinction between pressure, which can be a positive state if managed correctly, and stress which can be detrimental to health.

Stress at work can come about for a variety of reasons. It may be excessive workload, unreasonable expectations, or overly demanding work colleagues. As a reasonable organisation, we try to ensure that you are in a pleasant working environment and that you are as free from stress as possible.

Employees who experience unreasonable stress which they think may be caused by work should raise their concerns with their manager or through the Council's grievance procedure. If deemed appropriate, the Council will provide access to confidential counselling for employees affected by stress caused either by work or external factors

Following action to reduce the risks, they shall be reassessed. If the risks remain unsustainable by the employee concerned, efforts shall be made to reassign that person to other work for which the risks are assessed as tolerable.

Training

Training in health and safety is a legal requirement and also helps create competent employees at all levels within the Council to enable them make a far more effective contribution to health and safety, whether as individuals, teams or groups.

All employees will receive **induction training**.

Such training will cover:

fire procedures, warning systems, actions to be taken on receiving warning, locations of exits/escape routes, evacuation and assembly procedures, first aid/injury reporting procedures, names of first aiders/appointed persons, instruction on any prohibition areas (i.e. no smoking), issue of protective clothing/equipment and its use, instruction under COSHH, mandatory protection areas, thorough instruction applicable to their particular duties at work etc.

Training needs will be reviewed as a result of job changes, promotion, new activities or new technology, following an accident/incident and performance appraisal.

Records of training will be kept for all employees.

Employees must:

- participate in the induction training activities they have been required to attend or carry out;
- work according to the contents of any training they receive;
- ask for clarification of any points they do not fully understand;
- not operate hazardous plant or equipment, use hazardous chemicals or carry out any hazardous activity unless they have been appropriately trained and instructed.

Violence to Staff

The Council recognises that in certain situations violent behaviour towards staff may occur and therefore will take all reasonable measures to protect staff from violence and aggression.

We define violence and aggression as:

- actual or threatened physical assaults on staff;
- psychological abuse of staff;
- verbal abuse which includes shouting, swearing and gestures;
- threats against employees.

All staff must familiarise themselves with any relevant risk assessments to help them prevent violence and aggression so far as possible and to help them manage it if it occurs.

If you are a witness or receive any violence or aggression towards you, then you should report this to your manager so that this can be recorded and investigated. The Council will support the decision of any employee wishing to press charges against the individual(s) involved. Access to counselling can also be provided where required.

Visitors

In the interest of safety and security, the Council will take the necessary measures to protect staff and visitors from any accidents or incidents that may occur during visiting.

Employees hosting visitors must ensure that:

- they are authorised to enter the premises or are accompanied;;
- they adhere to applicable health and safety instructions and rules during their visit
- adequate information is passed to ensure their safety including emergency information;
- any protective clothing required is provided and worn;
- any accidents / incidents involving visitors are reported through the accident reporting arrangements.

Employees aware of people on the premises who may be unauthorised should report these to their manager for action.

Emergency Action

In the event of the fire alarm sounding, all visitors should be escorted to the assembly point by their host. Visitors should not leave the area before notifying the senior person present.

Waste Management

The Council manages all workplace waste in accordance with environmental and health & safety legislation. General and recyclable waste is segregated into clearly labelled containers. Employees must follow correct segregation and disposal procedures. All waste management practices are monitored, and records are maintained to ensure legal compliance and safe disposal.

Work At Height

The Council will take all reasonable steps to provide a safe working environment for all employees who may be affected by work at height activities.

The need to undertake work at height will be eliminated whenever it is reasonably practicable to do so. Where not practical, then the Council will ensure that all work activities that involve work at height are identified and assessed.

If working at height you must ensure that:

- the task has been assessed;
- suitable safety measures are in place;
- any equipment being used has been erected by a competent person and is safe to use;
- you only use equipment for which you have been trained and are authorised to use.

Ladders are permitted for light, short duration work only and must be checked in advance of use and be secured to prevent displacement.

Work Equipment

The Council will provide a safe working environment in relation to work equipment safety and ensure all employees receive appropriate safety information and training in their work equipment.

Employees must

- only use work equipment for which they have received information and training for;
- not undertake any maintenance work unless competent and authorised to do so;
- not interfere with or remove anything which has been provided for safety reasons;
- report defects immediately to their manager;
- use any personal protective equipment as required.

Control of Substances Hazardous to Health (COSHH)

There are a range of Hazardous Substances to which the regulations apply. These include:









- those classified and shown with warning label;
- substances with Occupational Exposure Limits;
- biological agents e.g. Legionella bacteria;
- any kind of dust;
- substances generated by work processes e.g. various bacteria/viruses from bodily fluids' premises with covered or underground parking that may expose people to vehicle exhaust fumes and some manufacturing and cleaning processes that may give off dusts, vapours or fumes.

Hazard Labelling

Hazardous substances may be defined as being toxic, corrosive, a health hazard, a serious health hazard, flammable, oxidising, explosive, harmful to the environment or gases stored under pressure.

Classification of hazardous substances is currently done under the Classification Labelling and Packaging (CLP) Regulations, which came into full effect in June 2015. These Regulations require hazardous substances to be packaged and labelled to an internationally agreed standard.

Hazardous substances can be readily identified by their label:

 Health hazard	 Corrosive	 Toxic
 Flammable	 Oxidising	 Harmful to the environment
 Serious health hazard	 Explosive	 Gas under pressure

Hazardous substances that are generated by work processes are not as easily identifiable as they do not come conveniently labelled. You will be informed of any hazardous substances generated by the Council's work processes.

Exposure Routes

Exposure to hazardous substances may be via:

- inhalation e.g. dust/ particulate or vapours/ fumes ;
- contact with eyes or cuts;
- absorption through the skin;
- ingestion;
- injection.

Hazard Effects

Effects on health may be short-term or long-term and will generally vary according to levels and duration of exposure. Effects of substances also vary with some having an accumulative effect and some that will have only temporary health effects.

Control Principles

The principles applied to substances to control exposure are:

1. elimination e.g. don't use the substance;
2. substitution e.g. a less hazardous substances;
3. engineering controls e.g. Local Exhaust Ventilation;
4. information, instruction, supervision and training;
5. Personal Protective Equipment (PPE) e.g. gloves, glasses, overalls.

Working with Hazardous Substances

Prior to working:

- ensure you understand the risks of working with any hazardous substances and the controls in place;
- ensure you know the location of the material safety data sheets and risk assessments;
- ensure the controls specified in the risk assessment, including any items for emergencies are:
 - in place
 - fully operational

- available
- ensure you understand how to operate or use any control measures safely and have received training prior to starting work.

Whilst working:

- ensure regular check controls are effective;
- clean up any spillages etc.;
- report any problems or defects immediately to your manager;
- report any ill-health or accidents to your manager.

Display Screen Equipment (DSE)

Getting comfortable

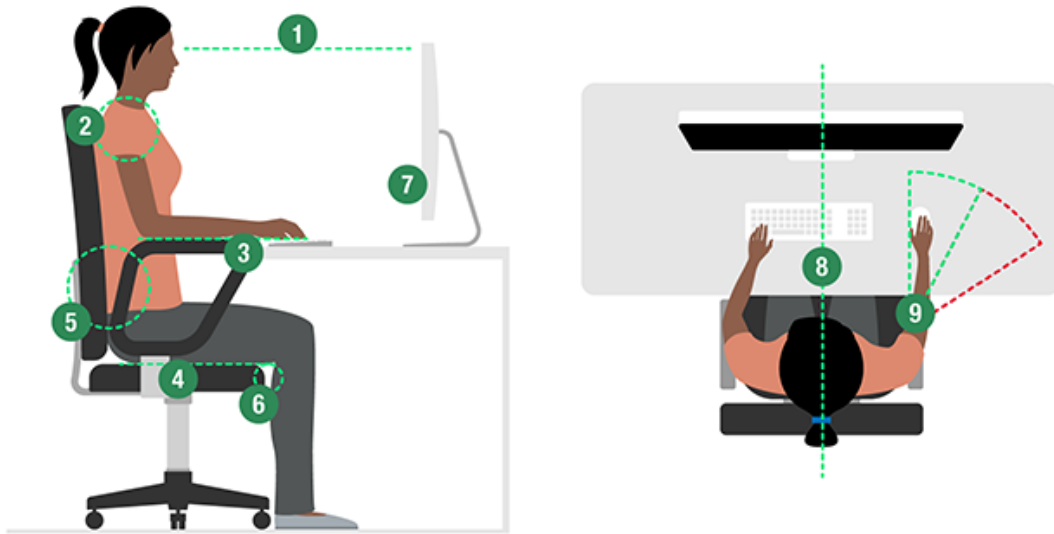

1. Top of screen level with eyes, about an arm's length away;
2. Relax your shoulders - try to position yourself high enough so you don't need to shrug your shoulders;
3. Keyboard just below elbow height;
4. Seat height equally supports front and back of thighs (or use cushion to raise seated position)
5. Back of the seat provides good lower back support (or use cushion, to provide additional back support);
6. Gap of 2-3 cm between front of seat bottom and back of knee;
7. Computer and screen directly in front of you on desk or another surface;
8. Screen and keyboard central - don't twist your back;
9. Mouse in line with elbow.

Laptop setup

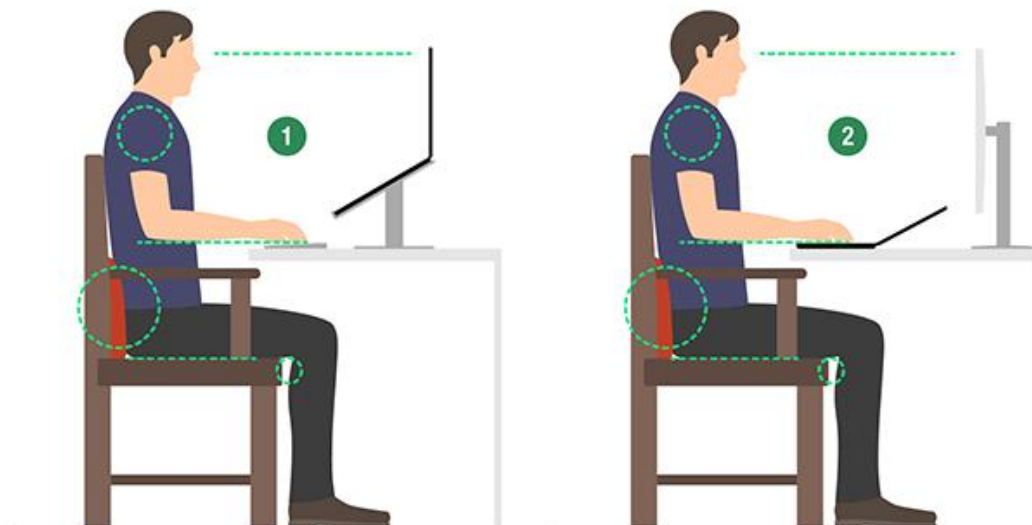

1. Keyboard and mouse separate from the laptop so screen can be elevated on a laptop riser or similar;

2. Display screen separate from the laptop.

Keying in

- Adjust your keyboard to get a good keying position. A space in front of the keyboard is sometimes helpful for resting the hands and wrists when not keying;
- Try to keep your wrists straight when keying. Keep a soft touch on the keys and don't overstretch your fingers. Good keyboard technique is important.

Using a mouse

- Position the mouse within easy reach, so it can be used with the wrist straight. Sit upright and close to the desk, so you don't have to work with your mouse arm stretched. Move the keyboard out of the way if it is not being used;
- Support your forearm on the desk, and don't grip the mouse too tightly;
- Rest your fingers lightly on the buttons and do not press them hard.

Reading the screen

- Adjust the brightness and contrast controls on the screen to suit lighting conditions in the room.
- Make sure the screen surface is clean;
- In setting up software, choose options giving text that is large enough to read easily on your screen, when you are sitting in a normal, comfortable working position. Select colours that are easy on the eye (avoid red text on a blue background, or vice-versa);
- Individual characters on the screen should be sharply focused and should not flicker or move. If they do, the VDU may need servicing or adjustment.

Posture and Breaks

- Don't sit in the same position for long periods. Make sure you change your posture as often as practicable. Some movement is desirable but avoid repeated stretching to reach things you need (if this happens a lot, rearrange your workstation);
- Most jobs provide opportunities to take a break from the screen, e.g. to do filing or photocopying. Make use of them. If there are no such natural breaks in your job, your employer should plan for you to have rest breaks. Frequent short breaks are better than fewer long ones.

Driving

Driving is the most dangerous work activity that most people do. Research indicates that around 20 people are killed and 250 seriously injured every week in crashes involving someone who was driving for work purposes. The Council encourages employees to follow the guidance given in order to minimise risk to themselves and other road users.

Vehicle Maintenance and Checks

Employees are required to ensure that their vehicles are maintained in accordance manufacturers recommended service intervals and are in a safe roadworthy and legal condition at all times. If your vehicle is over 3 years old, it requires an annual MOT test.

Regular vehicle checks should be carried out on vehicles by drivers, especially prior to undertaking a long journey.

Checks should include:

- oil, coolant and brake fluid levels;
- power steering fluid level;
- screen washer fluid level;
- wiper condition and operation;
- windscreen condition and cleanliness;
- tyre pressure, tread depth and general condition;
- all lights are working;
- seatbelts;
- bodywork.

If any faults are found that may affect vehicle safety, the vehicle **MUST NOT** be used until they are remedied.

Vehicle Breakdown

Breaking down can be a stressful and worrying experience, particularly if you are alone or in an unfamiliar place. It can also be hazardous. Following the basic safety guidelines below can help to reduce risk.

On motorway

If possible, leave the motorway at the next exit or pull into a service station.

If this is not possible then the hard shoulder should be used accordingly:

- use the hard shoulder lane to decelerate before stopping as far to the left as possible, preferably near an emergency telephone;
- turn on hazard warning lights along with sidelights if dark or visibility is poor. **DO NOT DISPLAY A RED TRIANGLE OR OTHER WARNING DEVICE;**
- get out of the car using the doors on the verge side. Ensure passengers vacate the vehicle the same way;
- take note of marker posts and contact the emergency services, where possible using an emergency phone instead of a mobile phone;
- if walking along the hard shoulder to a telephone, keep as far away from the traffic as possible;
- if you feel at risk from another person, return to your vehicle by the passenger door and lock all doors. Leave the vehicle again as soon as you feel danger has passed;
- **DO NOT** attempt even minor repairs;
- once the vehicle is repaired, return to the motorway using the hard shoulder to accelerate to merge fully with traffic in the first lane.

If you cannot get your vehicle onto the hard shoulder, switch on the hazard warning lights and only leave your vehicle when you can get safely clear of the carriageway.

You must **NEVER** use the motorway hard shoulder to:

- stop for a break, to eat or drink or to go to the toilet – use the service stations;
- use a mobile telephone;
- check a route or map.

Off the motorway

If your vehicle breaks down on an ordinary road or carriageway, you should:

- leave your car in as safe place as possible, ideally away from traffic;
- switch off the engine;
- switch on hazard warning lights along with sidelights if dark or visibility is poor;
- display a red triangle, if you have one, on same side of road at least 45 meters (147ft) behind;
- find the nearest telephone or use a mobile phone to phone for assistance;
- wait for assistance in a safe place, away from your vehicle, keeping clear of the road and traffic;
- **do not** stand between your vehicle and oncoming traffic as you may obscure lights.

Tyre Safety

You need good tyres to drive safely as they affect the steering, braking and acceleration of your vehicle. Faulty tyres work less efficiently and don't last as long; they could also mean a heavy fine and penalty points on your licence. It is against the law to have:

- car tyres with tread worn below 1.6mm;
- a mix of radial and cross ply tyres;
- over or under inflated tyres;
- tyres with cuts, lump, bulges or tears;
- the wrong sort of tyre fitted.

Tyre pressures and inflation

Refer to the manufacturer's handbook for guidance on recommended pressures for your vehicle. Care must be taken when inflating a tyre. Only fill the tyre to the manufacturer's recommended pressure for the type of driving to be undertaken. Do not use tyre inflation devices near to cuts / open wounds etc. Tyre pressures should be checked every 2 weeks and when the tyres are cold (pressures are raised when warm).

Accidents

Any accidents involving physical injury to an employee driving on council business (excluding commuting to and from work) or involving a member of the public must be reported through the Council's accident reporting procedures.

Mobile Phones

Research has shown that the potential for being involved in an accident whilst using a mobile phone can be significantly increased due to the individual concentrating more on the conversation than on their immediate surroundings.

It is illegal to use a hand-held mobile phone when driving, even when you are stationary, for example at traffic lights or in a queue of traffic. This includes making or receiving calls, taking pictures, text messaging or accessing the internet.

You may be prosecuted for using a hands-free mobile phone if you fail to have proper control of the vehicle. If you drive carelessly or dangerously when using any phone, the penalties can include disqualification, a large fine and up to two years imprisonment.



Mobile phones should be used in accordance with the Council's agreed policy when driving on council business.

Driver Fatigue

Research shows that physical fatigue and tiredness in drivers is a significant cause of accidents, particularly on motorways.

Drivers should recognise the signs of fatigue, which are:

- increased yawning;
- not remembering the last few minutes;
- jerking your head or body from the brink of falling asleep;
- losing concentration;
- car veering off the road.

If you feel sleepy while driving, get off the road into a safe parking area to take a break. In order to keep awake until reaching a suitable parking place, turn on the radio, open the window or increase the cold air ventilation.

To avoid fatigue, try the following tips:

- plan your journey to include a 15 minute break every 2 hours;
- drink coffee or high caffeine drink;
- don't start a long trip if already tired;
- ensure you have had sufficient sleep if starting early;
- avoid driving between midnight and 6am when you are most likely to feel sleepy.

Driver Eyesight

Drivers should be able to read a number plate at the legal distance of around 20 meters (65 feet), using any corrective appliances such as glasses or contact lenses. The general recommendation is to have eyesight tested every two years. Having an eyesight test will usually identify the majority of common eyesight conditions and also give clues about other less common diseases.

If there is any problem with the employee's vision, because of either injury or disease or following an eyesight test, the employee must notify their line manager immediately.

Adverse Weather

The British weather is unpredictable, and adverse weather can occur suddenly. If you drive regularly for work, you should ensure that you are prepared for the weather conditions. When adverse weather has been forecast, relevant details should be obtained to decide whether it is appropriate to travel.

Alternative methods of travel may be more suitable depending on the weather conditions. Driving in adverse weather should take account of visibility, ability to stop when roads are wet or icy and load etc being carried.

Poor Visibility

When visibility is seriously reduced you should drive at a safe distance with dipped headlights on. You may also use front and rear fog lights (in addition to the headlights) but you must switch them off when visibility improves.

Wet Weather

In wet weather, stopping distances will be at least double those required for stopping on dry roads. This is because your tyres have less grip on the road. In wet weather:

- you should keep well back from the vehicle in front. This will increase your ability to see and plan ahead;
- if the steering becomes unresponsive, it probably means that water is preventing the tyres from gripping the road. Ease off the accelerator and slow down gradually;
- the rain and spray from vehicles may make it difficult to see and be seen. Use dipped headlights.

Flooded roads

Occasionally roads become flooded when there is a high rainfall over a short period of time.

- don't attempt to cross if water seems too deep;
- drive slowly in first gear but keep the engine speed high by slipping the clutch to avoid stalling;
- avoid the deepest water;
- test brakes after driving through floods.

Icy and Snowy Weather

Great care should be taken when driving in icy or snowy weather. Vehicle drivers are advised to carry a spade, warm clothing, a warm drink and emergency food in case your vehicle breaks down.

When driving:

- keep well back from the vehicle in front as stopping distances can be ten times greater than on dry roads;
- take care when overtaking gritting vehicles;
- watch out for snowploughs, which may throw out snow on either side. Do not overtake them unless the lane you intend to use has been cleared;
- drive extremely carefully when the roads are icy. Avoid sudden actions as these could cause a skid.

Windy Weather

High side vehicles are most affected by windy weather, but a strong gust can blow a car off course. This can happen on stretches of road exposed to strong cross winds, or when passing bridges or gaps in hedges. In strong winds your vehicle may be affected by turbulence created by large vehicles. Motorcyclists are particularly affected, so keep well back from them when they are overtaking high-sided vehicles.

Personal Security

Lone driving forms part of the Council's policy regarding council vehicles, whether the driver is female or male. Below is a checklist for personal security when driving:

- keep the doors of the vehicle locked, especially when in towns to avoid 'car-jacking';
- keep valuables including briefcases etc. out of sight when driving and on parking. Lock whatever is to be left behind in the boot;
- when parking, if possible, drivers should use a manned car park and park near the exit. Reversing into parking spaces is also advised to allow drivers to drive off immediately;

- keep the vehicle well maintained and with a surplus of fuel for the planned journey or to the next planned rest break or refuelling point;
- keep a mobile phone with you to summon help or keep in contact with your manager / office;
- avoid eye contact with other drivers and do not get into personal confrontation;
- if you believe you are being followed, drive to a police station, if possible, or a crowded place;
- always approach the vehicle with the key alarm/sender in hand, and be aware of people around you;
- carry a torch (integral with the key if possible) to make locating the lock at night easier;
- look in the back seat before entering and lock the car once seated.

Alcohol and Drugs

Driving under the influence of alcohol or drugs (whether prescribed or illegal substances) is against the law. Drugs and alcohol can both seriously impair your ability to drive and the effects may last for a number of hours (or days). There is no safe limit of alcohol and drugs as their effects can be dependent on a number of personal factors.

Before driving, employees must ensure they are fit to drive and have a level of alcohol below the maximum limit allowed, ideally zero, and not under the influence of any drugs that may affect ability to drive (check with your pharmacist / GP for the effects of any prescribed or over-the-counter drugs).

If driving on council business this should be in accordance with the Council policy. Consumption of alcohol whilst driving is prohibited both during council time or whilst driving a council vehicle. The possession, use or distribution of drugs / substances for non-medical purposes is strictly forbidden.



Refuelling of Vehicles

Due to the risks of fire and explosion, when refuelling any vehicle, the following should be adhered to:

- do not use any naked flames whilst on the filling station forecourt;
- do not use mobile phones;
- do not smoke.

Care should also be taken when walking on the forecourt due to the possibility of spilt diesel and petrol being present.

If you are using an unfamiliar vehicle, check the fuel type prior to dispensing. If using diesel, gloves should be worn when refuelling.

Safe Speed

One of the most significant risks for drivers and road users is inappropriate speed. This includes both exceeding the speed limits and driving within the limits but in unsuitable conditions.

When driving you should observe the following guidance:

- ensure you know the national speed limits for the roads and vehicle you are driving;
- plan journeys allowing for poor weather, traffic delays etc.;
- obey posted speed limit signs at all times (even if late at night / early morning);
- reduce speeds for poor weather, busy roads, unfamiliar roads, high pedestrian activity etc.

Further Advice and Information

<http://think.direct.gov.uk/>

Electrical Safety

What are the hazards?

The main hazards are:

- contact with live parts causing shock / burns (normal mains voltage, 230 volts AC, can kill);
- faults which could cause fires;
- fire or explosion where electricity could be the source of ignition in a potentially flammable or explosive atmosphere, e.g. in a spray paint booth.

Ensure that:

- suspect or faulty equipment is taken out of use, labelled 'DO NOT USE' and kept secure until examined by a competent person;
- where possible, equipment, tools and power socket-outlets are switched off before plugging in or unplugging;
- equipment is switched off and/or unplugged before cleaning or making adjustments.

Visual checks on electrical equipment

1. Inspections and testing of all portable electrical equipment and the fixed electrical installations is the responsibility of the Council, though the responsibility for undertaking visual checks falls to all employees.

2. Around 95% of all faults or damage can be found by visual checks and this will involve checking:

- for damage to the cable covering, such as cuts and abrasions, apart from light scuffing, or non-standard repairs e.g. cable wrapped with electrical tape
- where the cable enters the plug. Internal wires - those covered by the outer sheath may be exposed or the cable may be loose and move within the plug
- for damage to the plug, such as the cracked casing, bent pins, evidence of overheating i.e. burn marks or discoloration

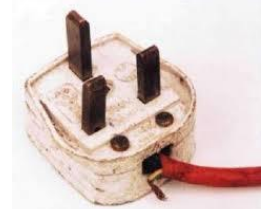

- for damage to the sockets, switches, etc. e.g. cracked or broken casing

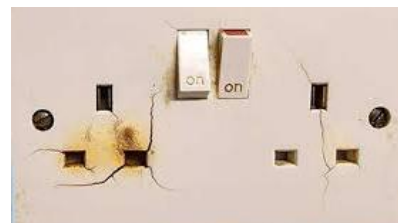

- that equipment has been used in conditions for which it is not suitable, e.g. a wet or dusty workplace or has damage to the outer cover of the equipment or has obvious loose parts or screws
- cables are routed safely, with the one extension lead used per socket. Where there is a risk of tripping over cables and they cannot be re-routed, cable strips must be fitted.

Hand Washing

It is important to look after your skin. Wash hands to remove any contamination from your skin promptly, and remember to dry your skin thoroughly after washing. Using moisturising creams can also help to protect your skin.

Regularly check your skin for dermatitis. Look for signs of dryness, itching and redness. If you think you may have dermatitis, report it to your manager.

Ladders and Stepladders

This guidance is to help you:

- know when to use a ladder;
- decide how to go about selecting the right sort of ladder for the particular job;
- understand how to use it;
- know how to look after it;
- take sensible safety precautions.

When is a ladder the most suitable access equipment?

As a guide, **only** use a ladder or stepladder:

- in one position for a maximum of 30 minutes;
- for light work - they are not suitable for strenuous or heavy work. If a task involves you carrying more than 10 kg up the ladder or steps it will need to be justified by a detailed manual handling assessment;
- where a handhold is available on the ladder or stepladder;
- where you can maintain three points of contact at the working position.

On a **ladder** where you cannot maintain a handhold, other than for a brief period of time, other measures will be needed to prevent a fall or reduce the consequences of one. On **stepladders** where a handhold is not practicable you will need to consider whether it is safe to work or not.

Is it a safe place to use a ladder or stepladder?

As a guide, **only** use a ladder or stepladder:

- on firm ground or spread the load (e.g. use a board);

- on level ground - for stepladders refer to the manufacturer's instructions, for ladders the maximum safe ground slopes on a suitable surface (unless the manufacturer states otherwise) are as follows:
 - side slope 16° – but the rungs still need to be levelled
 - back slope 6°
- on clean, solid surfaces (paving slabs, floors etc). These need to be clean (no oil, moss or leaf litter) and free of loose material (sand, packaging materials etc) so the feet can grip. Shiny floor surfaces can be slippery even without contamination.

Never stand ladders or stepladders on moveable objects, such as pallets, bricks, lift trucks, tower scaffolds, vans, stacks of paper or boxes etc. If the ladder or stepladder won't reach, you need to use a more suitable type of access equipment.

You should **only** use ladders or stepladders:

- where they will not be struck by vehicles, by protecting them with suitable barriers or cones;
- where they will not be pushed over by other hazards such as doors or windows, by securing doors (not fire exits) and windows where possible. If this is impractical, have a person standing guard at a doorway, or inform building occupants not to open windows until they are told it is safe to do so;
- where pedestrians are prevented from walking under them or near them, by using barriers, cones or, as a last resort, a person standing guard at the base.

Safety in use – ladders

On a ladder **do not**:

- overload it – you and anything you are carrying should not exceed the highest load stated on the ladder;
- overreach - keep your navel inside the stiles and both feet on the same rung throughout the task
- rest ladders against weak upper surfaces e.g. glazing or plastic gutters. Use effective spreader bars instead;
- use the top three rungs;
- move the ladder while someone is using it;
- extend a ladder while standing on the rungs;
- slide down the stiles.

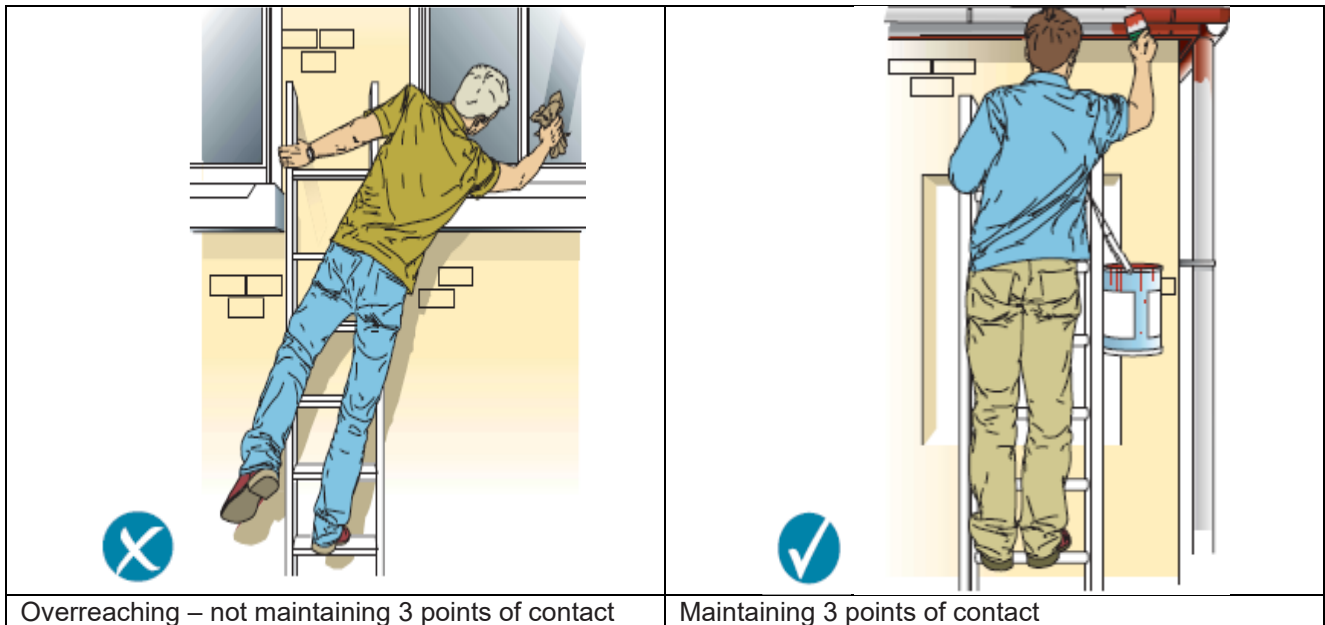

Do:

- make sure the ladder rungs are level. This can be judged by the naked eye. Ladders can be levelled using specially designed devices but not by using bits of brick or whatever else is at hand;
- check that the weather is suitable - do not use ladders in strong or gusting winds;
- wear sensible footwear. Shoes should not have the soles hanging off, have long or dangling laces, or be thick with mud or other slippery contaminants. High heels are also unsuitable!;
- check that you are fit. Certain medical conditions or medication, or a fear of heights, could mean that you shouldn't be working at height;
- know how to tie a ladder properly.

You should also avoid holding items when climbing (for example by using tool belts). If you must carry something you must still have one free hand to grip the ladder. Remember the **THREE POINTS OF CONTACT RULE** – 2 hands and 1 foot or 2 feet and 1 hand **MUST BE** on the ladder at all times when climbing and descending.

Ladders must be erected at an angle of 75°. To judge the angle use the angle indicator marked on the stiles of some ladders or the 1 in 4 rule (1 unit out for every 4 units up).

Ladders used for access to another level must be tied and should extend at least 1 metre above the landing point to provide a secure handhold.

Correct 1 in 4 angle:



Securing a ladder

To prevent the ladder slipping away from the wall, or slipping sideways, you must secure it. The options for securing a **ladder** are:

- tie the ladder to a suitable point, making sure both stiles are tied;
- where this is not practical, use a safe, unsecured ladder or a ladder supplemented with an effective ladder stability device;
- if this is not possible, then securely wedge the ladder e.g. against a wall;
- if none of the above can be achieved, foot the ladder. Footing is the last resort and other methods of securing the ladder should be used in preference.

If you do have to foot a ladder, be aware that this will not stop a ladder slipping sideways at the top. Individuals footing ladders should apply weight downwards on the ladder by standing on a rung, or by pushing against the ladder stiles (although this is less effective).

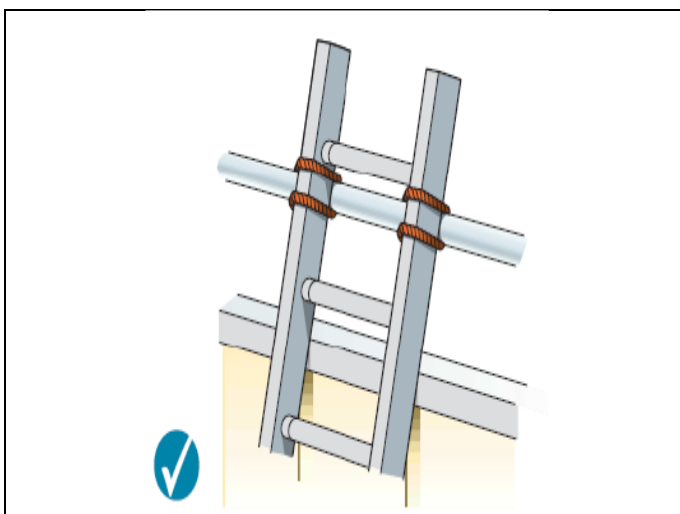

Ladder tied at the top stiles
(correct for working on, but not for access)

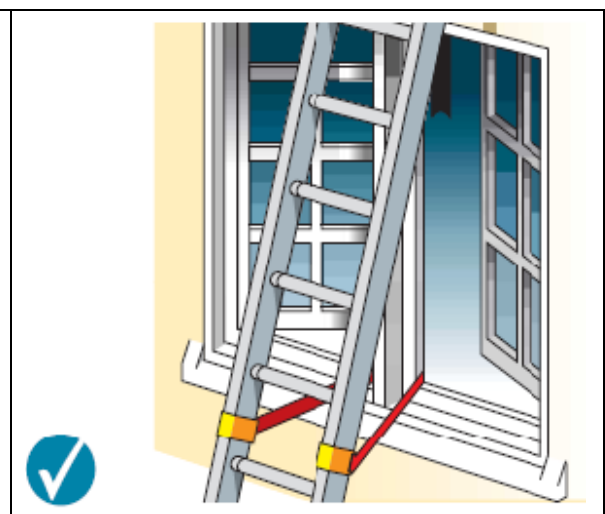

Tying part way down

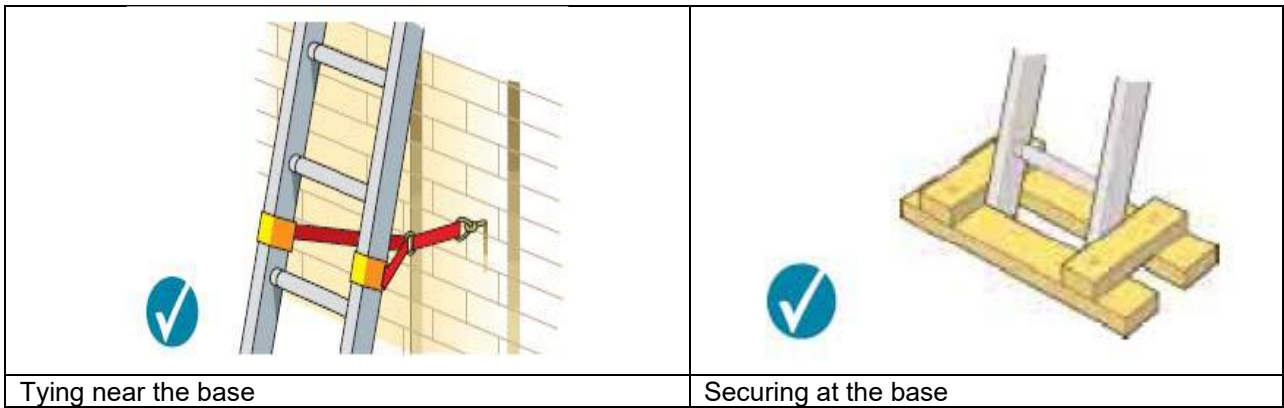

Safety in use – stepladders

On a stepladder **do not**:

- overload it – you and anything you are carrying should not exceed the highest load stated on the stepladder;
- use it in locations where the restraint devices cannot be fully opened. Any locking devices must also be engaged;
- use the top two steps of a stepladder, unless a suitable handrail is available on the stepladder;
- use the top three steps of swing-back or double-sided stepladders, where a step forms the very top of the stepladder.

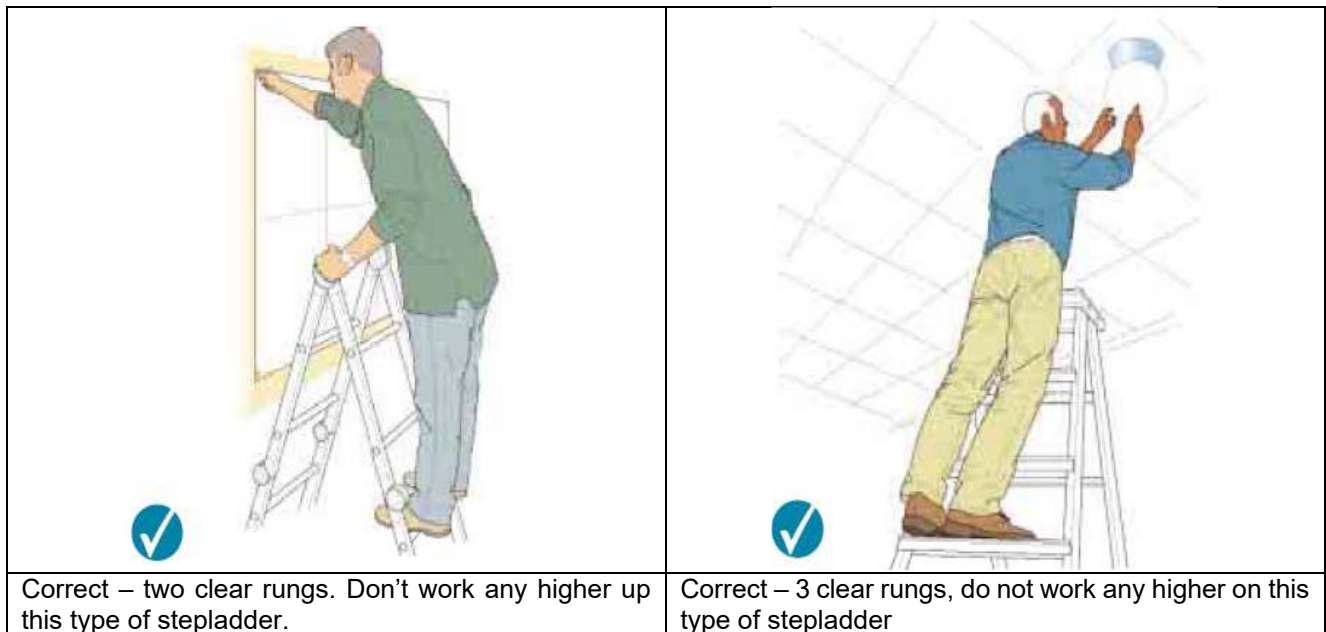

When using stepladders, avoid work that imposes a side loading, such as side-on drilling through solid materials (e.g. bricks or concrete), by having the steps facing the work activity. Where side-on loadings cannot be avoided you should prevent the steps from tipping over, for example by tying the steps to a suitable point, or you should use a more suitable type of access equipment.

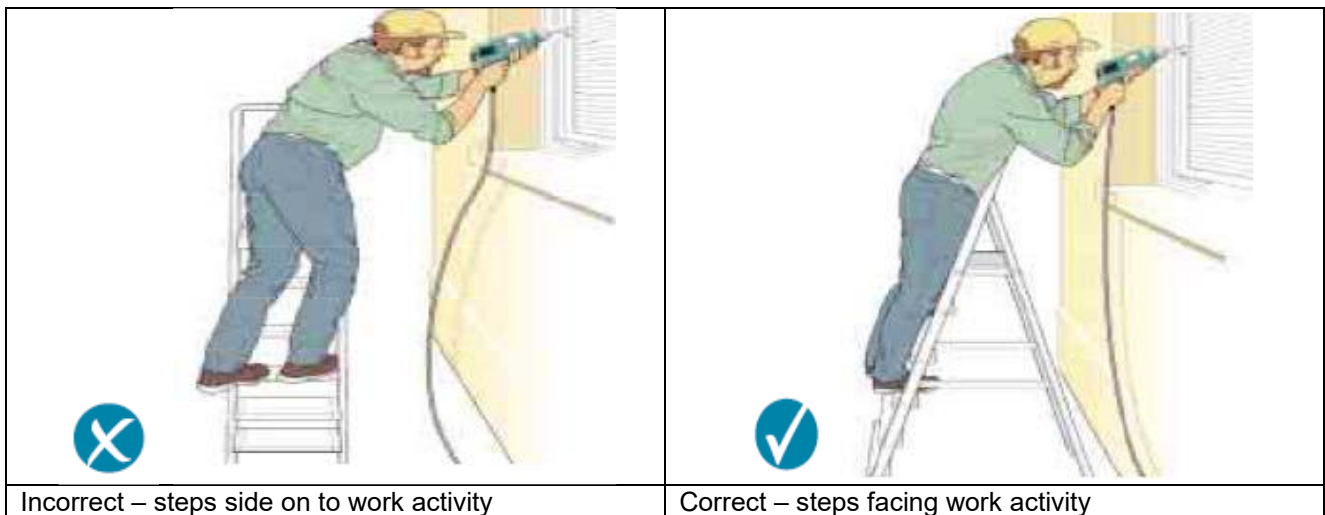

Where you cannot maintain a handhold (e.g. putting a box on a shelf), the use of a stepladder will have to be justified by taking into account:

- the height of the task;
- a safe handhold still being available on the stepladder;
- whether it is light work;
- whether it avoids side loading;
- whether it avoids overreaching;
- whether your feet are fully supported;
- whether you can tie the stepladder.

Consider tying a **stepladder** where possible and helpful to the task (e.g. side-on working or where two free hands are needed). Stepladders should not be used for access to another level unless they have been designed for this.

Is the ladder or stepladder safe to be used?

You must check that the ladder or stepladder is in a safe condition before using it (a daily pre-use check). As a guide, **only** use ladders or stepladders that:

- have no visible defects;
- have a current detailed visual inspection (look for an inspection label);
- are suitable for work use. Use EN 131 Professional ladders or stepladders at work because Non-Professional ones are not normally suitable for use at work;
- have been maintained and stored in accordance with the manufacturer's instructions.

Also, you must always use a non-conductive ladder or steps for any necessary live electrical work.

Pre-use checks

Look for obvious visual defects before using a ladder or stepladder. Check that:

- all the ladder feet are fitted;
- the feet are in good repair (not loose, missing, splitting, excessively worn, secure etc.);
- the feet are clean - the feet should be in contact with the ground. Ladder feet should also be checked when moving from soft/dirty ground (e.g. dug soil, loose sand/stone, a dirty workshop) to

a smooth, solid surface (e.g. paving slabs), to ensure the foot material and not the dirt (e.g. soil, embedded stones or swarf) is making contact with the ground;

- all the screws, bolts and hinges are secure;
- on a stepladder, that the “spreaders” on the ladder can be locked into place;
- There are no other obvious signs of damage such as cracks.

If you find a problem, DO NOT USE the ladder. It should be repaired (if practicable) or destroyed

Storage

When storing ladders and stepladders, store them in a well-ventilated area to prevent sagging and warping. Store straight ladders in flat racks or on wall brackets, don't hand them from the rungs. Store step ladders in the closed, vertical position.

Lone Working

There are certain circumstances where two staff must always be involved and specifically, that a safe system of work should be followed e.g. working in confined spaces. If you think that the job cannot or should not be done safely alone discuss it with your manager prior to starting.

Working alone can involve a number of scenarios. However, the following practical tips will apply to all of these:

- always tell someone, record where you are going, when you are going and your expected time of return;
- take a mobile phone with you and ensure that it is charged in case you need to use it;
- ensure your manager or colleagues have a record of your mobile telephone number;
- keep valuables / cash to a minimum;
- maintain regular contact with colleagues or manager.

Interviewing In Offices

There is a potential for violent crime against staff at all times, not least when interviewing or meeting members of the public in offices. The following general advice is given:

- ensure your manager or colleagues have a record of your mobile telephone number
- keep valuables / cash to a minimum;
- maintain regular contact with colleagues or your manager;
- assess the client prior to the meeting;
- notify staff in your department, recording who and where you are interviewing;
- ensure that there are always other members of staff available;
- if you have any doubts or fears do not interview alone, ask for another member of staff to assist;
- be constantly alert to signs of tension, frustration or aggression;
- when using any interview room ensure that your exit to the door is not impeded, always seat yourself nearest to the exit;
- prior to using an interview room ensure that there are no loose objects available which could be used as weapons;
- know how to summon help and ensure this remains accessible.

Walking

Anyone who is on foot should develop a sensible level of awareness to danger that is relevant to the circumstances. The use of a few sensible precautions should minimise risks:

1) Walking safely

- avoid short cuts through dimly lit or enclosed areas;
- after dark keep away from bushes, doorways and alleyways;
- tell your manager or colleagues your precise destination and expected time of return;
- walk facing oncoming traffic, this avoids a vehicle coasting quietly upon you from behind;
- walk confidently and purposefully, avoid sending out signals of fear and vulnerability;
- do not wear a personal stereo, it will reduce awareness of your surroundings;
- wear sensible footwear, do not wear footwear which may impede your actions if alarmed;
- if you think you are being followed, cross the street. If they continue to follow, move to the nearest place with people and call the Police using your mobile phone;
- keep your distance if asked for directions.

2) Carrying money and valuables safely

- don't carry more cash than absolutely necessary;
- keep wallets/purses in inside pockets;
- carry handbags close to the body, on the side away from the kerb;
- make sure the fastening on the bag is secure;
- if someone grabs your bag or wallet, let it go. Personal safety is paramount.

3) Be on guard with strangers

- be cautious in conversation; don't give away any personal details;
- trust your instincts and avoid crowds or groups which may appear threatening;
- be wary of stationary vehicles with engines running and people sitting in them;
- if a car stops and you are threatened, move away quickly in the opposite direction and use your mobile phone to call for assistance.

Driving

If you drive, a few sensible precautions will help minimise risks and help to make you more confident:

1) Before you set off

- make sure your vehicle is regularly serviced and check oil and tyres etc. regularly;
- ensure you have adequate fuel for the journey;
- plan your route;
- tell your manager or colleagues your precise destination and expected time of return.

2) On the road

- keep bags and other valuables out of sight – even during the journey;
- keep doors locked, windows and sunroof closed as much as possible, especially in stop/go traffic;
- do not pick-up hitch hikers;
- if followed, drive to the nearest police station or concentration of people and call for assistance using your mobile phone.

3) Leaving the vehicle

- always lock your vehicle and put anything of value out of sight;
- if dark or if it will be dark when returning to your vehicle, park in well lit places, as near to your destination as possible;
- wherever possible, use a manned car park;
- when parking, reverse your vehicle into a parking space and leave it as close to the exit as you can;
- have your keys ready when you return to your vehicle; check the interior for intruders before getting in.

4) If you break down



- pull off the road as far as you can and if necessary switch on your hazard warning lights;
- if someone offers help and you feel uncertain about them, stay in your vehicle (except on motorway) with the doors locked and use your mobile phone to summon assistance. Do not get into a car with a stranger or try to hitch a lift;
- summon assistance using your mobile phone and give precise details of your location.

5) If you feel threatened

- if you are being followed, drive to a busy place;
- if the occupants of a car beside you e.g. at traffic lights or road junction try to attract your attention for any reason, simply ignore them;
- if a car travels alongside you at the same speed, slow down and let them pass. If the driver persists, drive to a busy place and call the police;
- if a car pulls up in front of you, forcing you to stop, leave the engine running, activate your hazard warning lights and sound your horn continuously. If the driver gets out and approaches you, reverse and get away.

Manual Handling

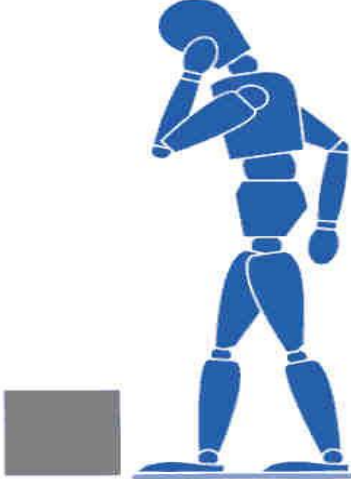
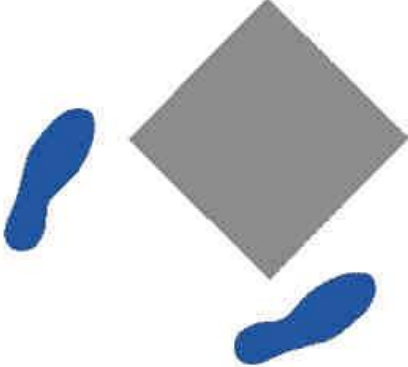
PRINCIPLES OF GOOD HANDLING TECHNIQUE

<p>1 Planning Plan the lift and consider: where the load is to be placed, what are the distances involved, are there any obstructions such as closed doors, is assistance required, and can handling aids or equipment be used?</p>	
<p>2 Feet The feet should be positioned a shoulder width apart, one foot ahead of the other in the direction of the intended movement.</p>	
<p>3 Knees Adopt a good posture for handling with the knees bent (not squat – don't kneel), in order to gain the most effective power from the thigh muscles.</p>	
<p>4 Back The back should be straight (not necessarily vertical, 15 - 20° from vertical is alright) keeping the natural curve of the spine. It may help to tuck in the chin. If necessary, lean forward a little over the load to get a good grip and to keep the centre of gravity over the load.</p>	
<p>5 Arms The arms should be close to the body (nearer the centre of gravity) with the shoulders level and facing the same direction as the hips.</p>	
<p>6 Hands Ensure a firm grip on the load using the roots of the fingers and the palm of the hand. Holding the load this way is also less tiring than keeping the fingers straight.</p>	
<p>7 Head Raise the chin out and up as the lift begins, otherwise this results in round shoulders and a curved spine.</p>	

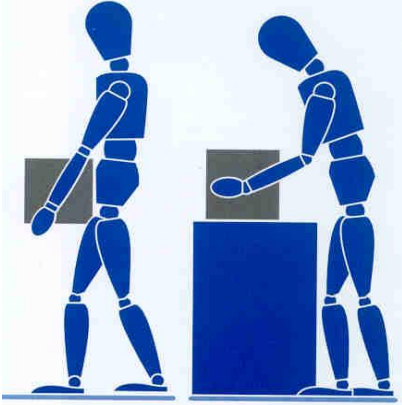
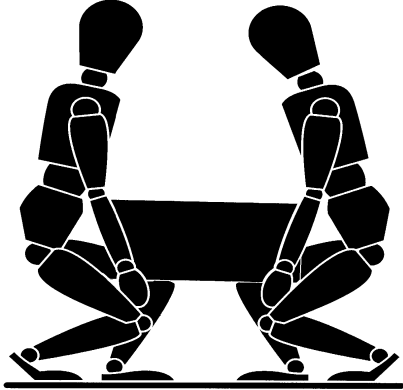
<p>8 Moving the Load Keep the load as close to the trunk for as long as possible, and where relevant, keep the heaviest side of the load close to the body. Slide the load towards you if required.</p> <ul style="list-style-type: none"> • Lift smoothly; • Move the feet not the trunk when turning to the side i.e. don't twist; • Put the load down and then slide the load into the required position if necessary. 	
<p>9 Team handling Handling by two or more people may make possible an operation that is beyond the capability of one person or reduce the risk of injury to a solo handler.</p>	
<p>Additional difficulties may arise if team members impede each other's vision or movement, or if the load offers insufficient good handholds. This can occur particularly with compact loads which force the handlers to work close together or where the space available for movement is limited.</p>	
<p>When lifting loads at or near floor level is unavoidable, it is preferable to use handling techniques which allow the use of relatively strong leg muscles rather than those of the back, provided the load is small enough to be held close to the trunk. In addition, if the task includes lifting to shoulder height, allow the handlers to change hand grip. Bear in mind however, that such techniques impose heavy forces on the knees and hip joints which must carry both the weight of the load and the weight of the rest of the body.</p>	
<p>The closeness of the load to the body can also be influenced by foot placement. The elimination of obstacles which need to be reached over or into will permit the handler's feet to be placed beneath or adjacent to the load before beginning the manual handling operation.</p>	

Violence and Aggression

Work-related violence has serious consequences for employees and the Council. Victims may suffer not only physical injury, but also psychological effects, such as anxiety and stress. The Council will take reasonable measures to protect you from acts of violence and aggression.

What is meant by violence?

An act of violence can be defined as:

- actual or threatened physical assaults on staff;
- psychological abuse of staff;
- verbal abuse which includes shouting, swearing and gestures;
- threats against employees.



How will the Council support you?

There are a wide range of measures that the Council will follow to reduce the risk of violence at work to employees. The Council will:

- carry out risk assessments of potential conflict situations to determine the control measures necessary to protect staff;
- ensure that premises are kept secure;
- inform all employees of the procedure following a violent or challenging behaviour incident;
- not tolerate violence or challenging behaviour towards our employees;
- train employees who may be exposed to violence or challenging behaviour situations;
- support any employees involved in any incident;
- support their decisions regarding the pressing of criminal charges;
- provide any counselling or post-incident assistance required by the employees;
- keep records of all incidents of violence and aggression and review the control measures with a view to continual improvement in employee safety.

Diffusing the situation

In the event of violent or aggressive behaviour towards you there are several steps that you can try to diffuse the situation:

- **Act in control:** Even if you feel anxious or scared when confronted by an aggressor, try to give the impression that you are confident and in control of the situation. Anxiety is an entirely reasonable reaction to violent or aggressive behaviour, but if an aggressor notices it then it may increase their level of aggression.
- **Adopt a calm approach:**
 - Talk to the aggressor in a calm and respectful manner and keep the tone of your voice low;
 - If you have been summoned to assist with a violent or aggressive customer or person that you don't know, introduce yourself to the aggressor and ask what you can do to help;
 - Maintain a non-judgmental attitude and focus your attention on the aggressor at all times;
 - Let the aggressor talk without interruption and acknowledge how they are feeling. Remember that your aim is to calm them down, not to make sense of their complaint or issue.
- **Use body language:** Body language can reinforce or undermine the impression that you are trying to give.
 - Maintain neutral eye contact with the aggressor but try not to stare. Break eye contact every so often if necessary;
 - Keep your face relaxed, but don't smile. The aggressor will respond badly if they think that you are laughing at them or making light of the situation;
 - Keep your body language open and don't cross your arms or gesture with anything that could be perceived as a weapon. Stand a safe distance away from the aggressor and be aware of your nearest exit at all times.
- **Work towards a solution:** Wait for the aggressor to calm down. Explain the consequences of their aggressive behaviour respectfully but firmly. Suggest ways in which the situation could be resolved without conflict, and try to give the aggressor more than one solution so that they have some control over the situation.

If you are a witness or receive any violence or aggression towards you, then you should report this to your manager so that this can be recorded and investigated. The Council will support the decision of any employee wishing to press charges against the individual(s) involved. Access to counselling can also be provided where required.